

Therm-A-Glaze 60

Part of the Dixon
International Group Ltd
www.dig.co.uk

Introduction

THERM-A-GLAZE 60 has been developed to provide a reliable 60 minute glazing system for timber fire doors. Timber doors present particular problems in 60 minute applications using uninsulated glass due to the high temperature of the glass and the erosion of the door and beads during a fire test.

The Product

THERM-A-GLAZE 60 is a unique set of seals which has been developed for 60 minute glazing applications to satisfy the demand for a completely dry system. The seal between the glass and the bead is Therm-A-Bead and the seal around the perimeter of the aperture is Therm-A-Line.

Application

THERM-A-GLAZE 60 is designed to provide fire resisting protection to glazed openings in timber fire doors in conjunction with suitable fire resisting glass and timber glazing beads.

Description

THERM-A-GLAZE 60 is a one hour glazing system comprising of the following components:

THERM-A-LINE – a specially formulated intumescent with erosion resistant qualities.
THERM-A-BEAD – a moderate expansion phosphate based intumescent contained in a pvc sleeve designed to give a pleasing finish and which expands in a fire to partially cover the beads providing extra protection from radiant heat.

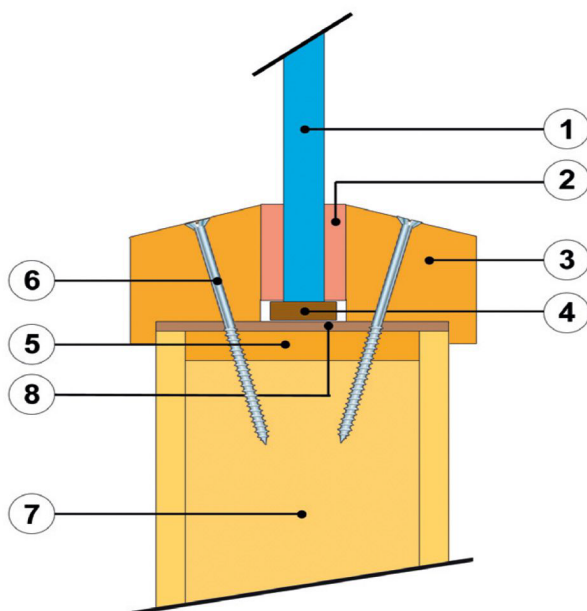

1. Glass
2. THERM-A-BEAD intumescent glazing seal 25 x 4mm
3. Hardwood glazing beads (min. density 650 kg/m³) 30mm wide by 25mm high incorporating a 5 x 5mm bolection return, chamfered by approximately 20°
4. Non-combustible/hardwood setting blocks
5. 16mm hardwood (min density 650 kg/m³) liner
6. No.8 Screws, 50mm long at 150mm centres
7. Nominally 54mm thick FD60 door leaf
8. 54 x 2mm THERM-A-LINE intumescent liner or as required to accommodate beads and glass at the required dimensions

Therm-A-Glaze 60

Part of the Dixon
International Group Ltd
www.dig.co.uk

Availability

THERM-A-GLAZE 60 is supplied as a complete system in the following sizes:

THERM-A-LINE 2100mm x 54mm x 2mm
 2100mm x 45mm x 2mm

The standard colour of THERM-A-LINE is pink but other colours can be supplied to order.

THERM-A-BEAD 2100mm x 25mm x 4mm

The pvc sleeve is available in brown, white, cream, red, black.*

Test Evidence

THERM-A-GLAZE 60 has been successfully tested as a component of various door sets and glazed screens to meet the fire resistance requirements of BS476:Part 20 & 22. It has also been certified to the more exacting standards required by Certifire. See Intumescent Seals certificate CF 284 on www.warringtonfire.net/certifire/products/glass-and-glazing for details.

It is currently being evaluated to the requirements of BS EN 1634-1.

Copies of test reports and assessment evidence are available on request.

Related Products

Improved glazing performance may be obtained by combining THERM-A-GLAZE 60 with other intumescent products in certain circumstances. Contact our Technical Department for further information.

Contacting Us

Intumescent Seals
Unit 3
The Old Brewery,
Pampisford,
Cambridge,
CB22 3EW
England.

Tel. (01223) 832758
Fax (01223) 837215
info@intumescentseals.co.uk
www.intumescentseals.co.uk



Intumescent Fire Seals Association



* Colours may vary slightly between examples illustrated in print, online and actual examples - which will depend upon lighting conditions in situ.